

# 7SG26 Tau

Auto Re-close

## Document Release History

This document is issue 2010/02. The list of revisions up to and including this issue is:  
Pre release

2010/02	Document reformat due to rebrand
---------	----------------------------------

## Software Revision History

The copyright and other intellectual property rights in this document, and in any model or article produced from it (and including any registered or unregistered design rights) are the property of Siemens Protection Devices Limited. No part of this document shall be reproduced or modified or stored in another form, in any data retrieval system, without the permission of Siemens Protection Devices Limited, nor shall any model or article be reproduced from this document unless Siemens Protection Devices Limited consent.

While the information and guidance given in this document is believed to be correct, no liability shall be accepted for any loss or damage caused by any error or omission, whether such error or omission is the result of negligence or any other cause. Any and all such liability is disclaimed.

## Contents

1. REQUIRED TEST EQUIPMENT .....	3
2. INSPECTION .....	3
3. APPLYING SETTINGS .....	3
4. PRECAUTIONS .....	3
5. TESTS.....	3
5.1 Insulation .....	3
5.2 Commissioning Tests.....	4
5.2.1 Status input tests .....	4
5.2.2 Output relay tests .....	4
5.2.3 Measurement Tests.....	5
5.2.4 Scheme Tests.....	5
6. PUTTING INTO SERVICE .....	13
APPENDIX 1 – Test Tables .....	14
APPENDIX 2 - Circuit Breaker Simulation Circuit .....	15

## Table of Figures

Figure 1 CB In Service.....	9
Figure 2 Trip And Autoreclose.....	10
Figure 3 Autoreclose Timers.....	11
Figure A1 .....	15
Figure A2 .....	15

## 1. REQUIRED TEST EQUIPMENT

The following equipment will be required to perform commissioning tests on the relay.

- 500V Insulation resistance test set.
- Two variable A.C. voltage sources with a means of varying the phase relationship between them e.g. phase shifting transformer. Ideally, a portable relay test set e.g. Doble, Omicron etc.
- Time interval meter.
- 2 A.C. Voltmeters.
- Phase angle meter.
- D.C. supply with nominal voltage within the working range of the relay's D.C. auxiliary supply rating.
- D.C. supply with nominal voltage within the working range of the relay's D.C. status input rating.
- Continuity tester e.g. multimeter.

Additional equipment for testing the communications channel:

- Portable PC with an electrical-to-optical RS232 converter and fibre optic connectors.
- A copy of Reydisp Evolution software installed on the PC to exercise the communications channel.

## 2. INSPECTION

Check that the relay has not been damaged in any way since being installed into the panel. Check that the serial numbers of the relay, the case and the relay cover are all identical. Check also that the relay is the correct model and that the rating is correct.

Ensure that all connections are tight and in accordance with the relay wiring diagram or the scheme diagram. Check that all the modules are fully connected and inserted. Ensure that the relay case is solidly bonded to a local earth point by checking the earthing connection to the case.

## 3. APPLYING SETTINGS

Before applying settings to the relay the engineers should take time out to familiarise themselves with the relay's menu system. Section 1 and section 3 of this manual are helpful in this respect. The relay settings for the particular application should be applied before any secondary testing occurs. If they are not available then the relay has default settings which can be used for pre-commissioning tests. See section 3 of this manual for a list of the relay default settings.

Settings can be entered into the relay using the keypad on the front of the relay or they can be sent to the relay, from a file, using a portable PC and Reydisp Evolution software package.

Tau relays feature four alternative setting groups. In applications where more than one setting group is to be used then it may be necessary to test the relay in more than one configuration.

Note : when using setting groups it is important to remember that the relay need not necessarily be operating according to the settings which are currently being displayed. There is an "active setting group" on which the relay operates and an "edit/view setting group" which allows the settings in one group to be viewed and altered while protection continues to operate on a different unaffected group. The "active setting group" and the "edit setting group" are selected in the "System Configuration Menu".

## 4. PRECAUTIONS

Before testing commences the relay should be isolated from the voltage transformers in line with the local site procedures. The closing and alarm circuits should also be isolated where practical. Ensure that the correct d.c. auxiliary voltage is applied to the circuit. See the relevant scheme diagrams for the relay connections.

## 5. TESTS

### 5.1. Insulation

Connect together all of the V.T. terminals and measure the insulation resistance between these terminals and all of the other relay terminals connected together and to earth.

Connect together the terminals of the DC auxiliary supply circuit and measure the insulation resistance between these terminals and all of the other relay terminals connected together and to earth.

Connect together the terminals of the DC status input circuits and measure the insulation resistance between these terminals and all of the other relay terminals connected together and to earth.

Connect together the terminals of the output relay circuits and measure the insulation resistance between these terminals and all of the other relay terminals connected together and to earth.

Satisfactory values for the various readings above depend upon the amount of wiring concerned. Where considerable multi-core wiring is involved a reading of 2.5 to 3.0 M $\Omega$  can be considered satisfactory. For short lengths of wiring higher values can be expected. A value of 1.0 M $\Omega$  should not be considered satisfactory and should be investigated.

Remove temporary connections.

## 5.2. Commissioning Tests

Select the required relay configuration and settings for the application.

### 5.2.1. Status input tests

This test checks that the status input circuits are functioning correctly. The status input circuits should be energised in turn and observed to be operating using the Instruments mode 'Status Inputs 1-27' display. A '1' indicates that the status circuit is energised, a '0' indicates that it is not.

Connect the correct D.C. voltage to the following terminals to energise the status inputs :

Status Input	+ DC Volts	- DC Volts
Status 1	A21	A23
Status 2	A25	A27
Status 3	A26	A28
Status 4	B1	B3
Status 5	B5	B7
Status 6	B9	B11
Status 7	B13	B15
Status 8	B17	B21
Status 9	B19	B21
Status 10	B23	B27
Status 11	B25	B27
Status 12	C2	C4
Status 13	C6	C8
Status 14	C10	C12
Status 15	C14	C16
Status 16	C18	C22
Status 17	C20	C22
Status 18	C24	C28
Status 19	C26	C28
Status 20	C1	C3
Status 21	C5	C7
Status 22	C9	C11
Status 23	C13	C15
Status 24	C17	C21
Status 25	C19	C21
Status 26	C23	C27
Status 27	C25	C27

### 5.2.2. Output relay tests

This test checks that the output relays are functioning correctly. The output relays should be energised in turn and the contacts should be checked for correct operation using a continuity

tester. The output relays can be energised in a number of ways. The following is the recommended method :

Assign each output relay in turn to 'Protection Healthy' in the output relay menu. On pressing the ENTER key the output relay selected will be energised. Check with a continuity tester that the actual contacts have operated. De-select the output relay and check that the contact returns.

Output Relay	Type	Terminal No.
Relay 1	N/O	A4 – A5
Relay 1	N/C	A5 – A6
Relay 2	N/O	A8 – A9
Relay 2	N/C	A7 – A8
Relay 3	N/O	A10 – A12
Relay 3	N/C	A11 – A12
Relay 4	N/O	A17 – A19
Relay 5	N/O	A18 – A20
Relay 6	N/O	B2 – B4
Relay 7	N/O	B6 – B8
Relay 8	N/O	B10 – B12
Relay 9	N/O	B14 – B16
Relay 10	N/O	B18 – B22
Relay 11	N/O	B20 – B22
Relay 12	N/O	B24 – B28
Relay 13	N/O	B26 – B28

Note : when finished testing the output relays make sure that the 'Relay healthy' is re-assigned to the correct output relay given in the settings file.

### 5.2.3. Measurement Tests

Apply A.C.volts to both of the voltage input circuits of the relay using the A.C. variable voltage sources or portable relay test set. The relay should display the correct value of voltage  $\pm 5\%$  which is the tolerance of the measurement display meters. The instruments mode 'Line RMS' and 'Bus RMS' meters display the secondary voltage levels.

The applied A.C. volts can be in the range of 5 – 200Vrms. Nominal volts of 63.5V.

### 5.2.4. Scheme Tests

It is not necessary to perform tests on all internal elements of the relay. If the settings have been checked, the external wiring checked, the status inputs and output relays verified and the relay measures satisfactorily then the relay can be deemed to be working to its design requirements. It will operate correctly, to the performance claims, and its operation under all service conditions is guaranteed.

However, if added confidence is required, then the following elements can be checked. Note that the relay should be commissioned with the actual settings calculated for the particular scheme.

Autoreclose schemes vary between different utilities. Some of the functions such as Block Reclose are used differently. Therefore it is important that tests are carried out with relevance to the engineered scheme.

The purpose of these tests is to confirm the correct operation of the status and control inputs. Some of the tests will require the application of voltage.

In order to ensure that all operations proceed correctly, the following should be observed:

- A working circuit breaker, complete with auxiliary supplies, should be connected to the relay, if possible; if not, then an electronic circuit simulating the circuit breaker operation may be used instead. See Appendix 2. If this is not available a switch may suffice, care will be required with settings. Or alternatively the test equipment may provide a CB control circuit.

- Throughout the tests, a close pulse length should be selected which is suitable for the circuit breaker or simulation circuit, given that the CB closing operation must be complete, before the close pulse is removed by the relay.

To facilitate ease of commissioning a meter is included in the instruments which shows what state the autoreclose sequence has reached. The states are as follows:

**StartUpLockout:** Temporarily displayed after power on.

**AROutOfService:** When the relay is switched Out Of Service either at start up or from the idle state.

**InServiceLockout:** When switching IN from Out Of Service there is a temporary switch in lockout.

**Idle:** quiescent state, waiting for an autoreclose sequence to begin.

**Lockout:** Lockout state. No Autoreclosing allowed.

The Autoreclose sequence is performed with the following states:

**SequenceInProgress:** AR Start. A trip has occurred and the CB was in service whilst in idle. Will wait for AR Primed conditions: CB Open AND Trip reset AND Dead Line.

**SecDeadTimeInitiate:** A trip within the first close pulse or first reclaim and a second reclose is allowed. Will wait for AR Primed conditions: CB Open AND Trip reset AND Dead Line.

**SingleFirstDeadTime, ThreeFirstDeadTime, SingleSecDeadTime, ThreeSecondDeadTime:** The autoreclose deadtime.

**FirstCloseInhibit, SecondCloseInhibit:** At the end of the deadtime if waiting for synchronisation or Block Reclose to reset then will be in this state.

**FirstClosePulse, SecondClosePulse:** The Close Pulse is being issued.

**FirstReclaim, SecondReclaim:** checking for correct reclose.

The Manual Closing sequence is performed with the following states:

**ManualClose:** Wait for correct close conditions, i.e. synchronisation.

**ManualClosePulse:** The Close Pulse is being issued.

**ManualReclaim:** checking for correct close.

After receiving the relay the default position is Out Of Service, therefore at power up the meter will display StartUpLockout to AROutOfService.

With the state displaying AROutOfService an A/R IN signal is required to switch in the relay. The meter will then display InServiceLockout to Idle. There should be a 4 second delay while the relay is temporarily in Lockout.

Idle is the quiescent state when waiting for an autoreclose sequence to begin. This should be the initial displayed state when performing the majority of the tests.

## 1. Phase Angle Tests

The CS Phase Angle detector and the SS Phase Angle detector can be tested in the following way:

Apply nominal volts to both the line and bus input terminals of the relay. On initial turn on, the relay will start in check synchronising mode. If the voltage vectors are displaced by an amount greater than the CS Phase Angle setting but not as much as the System Split Detector angle then the relay will stay in check synchronising mode. Using the instruments display, locate the Phase Angle instrument as shown below:

**Phase Angle**  
**0.0°**

Check the Check Sync Angle setting in the SYNC MENU. Assign an unused LED to indicate In Sync i.e. L = 16. At switch on, the relay has a 2sec. delay before In Sync is issued, but if voltages are continuously applied and only the phase angle changed the In Sync LED can then be used to check pick-up and drop-off of the Check Sync function. Apply voltage, after 2 sec the

LED will come on, Slowly increase the phase angle past the setting so that the LED goes out. Slowly bring in the phase angle and check the pick up. Then slowly increase the phase angle and check the drop off. The pick up and drop off values should fall within the performance claims given in Section 2 - Performance Specification subsection 6. Repeat for opposite angles.

Note : the phase angle should be adjusted slowly so that the LCD has time to update. The instrument has a delay on updating.

This test should be repeated for the system synchronising settings. This is best carried out by increasing the phase angle until a split occurs and then bringing the angles in. The split will cause the relay to go into system synchronising mode.

The results can be put into Table 1 at the back of this section.

## 2. Slip Frequency Tests

The CS Slip Frequency detector and SS Slip Frequency detector elements are more difficult to test and require variable frequency sources. A portable relay test set is ideal for this.

Depending on the relay scheme settings it may be difficult to test the CS and SS slip frequency elements independently without adjusting the settings.

To test the CS Slip Frequency element turn the Split Angle to OFF. This will ensure that a split does not happen and the relay is in check sync mode. Increase the frequency slip to a value outside of the slip frequency limits and then slowly reduce it until the element picks up. This will be indicated on the same LED as above. Gradually increase the slip until the element drops off as indicated. Record the results in Table 2.

To test the SS Slip Frequency element turn the Split Angle back to the value required for the scheme. System Sync only occurs after a system split. Turn CS Slip Frequency element to OFF. Increase the phase angle until a split occurs and then repeat the above tests. Record the results in Table 2.

To test the Close On Zero (COZ) function an Omicron test set or similar should be used. This function closes when the two voltages are in phase. Using Check Sync or System Sync the relay will always close just after it passes the set limits. With Close On Zero the relay uses the CB Closing time and works out from the slip frequency the point at which the two voltages are at actual zero phase angle. COZ is part of the reclosing scheme and can only proceed when an autoreclose sequence or a Manual Close is issued after a system split. The easiest way to test this function is to use a Manual Close input. The setting MC Split Action should be set to Close On Zero. The test equipment can be used to stop recording from a Close Pulse output relay. Make sure that all Closing links are removed prior to the test. The following sequence can be used to test the COZ function: Increase the phase angle until a split occurs, the CB should be open, issue Manual Close, decrease the phase angle until a close pulse is issued. Make sure that the time it takes to decrease the phase angle is not greater than the Sync Close delay otherwise the relay will go to Lockout before the test is complete. Record the results in Table 2.

All the results should fall within the performance claims given in Section 2 - Performance Specification.

Note : remember to return all settings back to the original scheme settings if they have had to be changed.

## 3. Timer Tests

The Check Sync Timer and System Sync Timer can be tested by setting the angle between the two voltages to a value outside of the phase angle settings. Reduce the phase angle to zero and the output should not close until after the timer has timed out.

In practice however, the timers are difficult to test without specialist test equipment and test software. There are three recommended methods:

1. Apply in phase nominal volts to the relay. The relay will issue a close only after the timer has timed out. Note, however, that the relay has a start-up timer of 2sec. which is the minimum time before an output is given. This start-up timer effectively runs in parallel with the timer. If for example a Check Sync Time of 2.0sec has been selected then the time for close will be 2.0sec. If however, 0.5sec has been selected then the time for close will be 2.0sec.
2. Apply in phase volts to the relay at a level below the undervoltage blocking element level. The relay will time through the start-up timer. If the volts are then increased to nominal then the relay will close after the set slip time. If 0.5sec has been selected then the relay will close after 0.5sec.

All results should fall within the performance claims given in Section 2 - Performance Specification.

3. Using Reydisp Evolution software the event records will give accurate times for all of the timing events within the relay. The following events were extracted from a relay which had the Check Sync Timer set to 1.0 sec. When the phase angle moved inside the close window the actual close output was given after a time of 1.005 seconds.

09:08:43.020 , 21/02/00 Rey Raised In Sync

09:08:44.025 , 21/02/00 IEC Raised CB 'on' by AR

#### 4. Voltage Detectors

Check the pick up and drop off levels for the voltage detector elements. Individually ramp up and down the line and bus volts and examine a Live Line / Live Bus LED indication to see where the elements actually operate. Record the results in Table 4.

#### 5. Undervoltage Elements

Check the pick up and drop off levels for both the line undervoltage and bus undervoltage blocking elements. The In Sync indication is derived from In Phase AND No Slip AND No Differential AND Not Undervolts. Apply voltage from the same source to the Line and Bus inputs, decrease the voltage until the In Sync LED goes out, then increase the voltage until the LED comes back on. It is better to set the Check Sync timer to zero for this test. Separate results for the Line and Bus can be recorded by varying the Undervolts settings. Record the results in Table 4.

#### 6. Differential Voltage Elements

Check the pick up and drop off levels for the differential voltage blocking element. Apply different voltages to the Line and Bus. Keep the voltages in phase and no slip and above the undervoltage levels. The In Sync LED will go out when the Voltage Differential setting goes above the setting. Record the results in Table 4.

All results should fall within the performance claims given in Section 2 - Performance Specification.

#### 7. A/R In/Out Switching

The relay can be switched out at any point. The commissioning to confirm the action of the In/Out switching mechanism requires a full understanding of how this function works. A/R Out has priority over A/R In. This function can be used as an Autoreclose Inhibit.

Energise A/R Out and check for A/R Out of Service indication. Check in the instruments mode that Autoreclose State displays AROutOfService.

Energise A/R In and not A/R Out, the relay should then go back to indicate A/R In Service. Whilst performing the test check in the instruments mode that the Autoreclose State progresses from displaying AROutOfService to InServiceLockout to Idle.

With both A/R In and A/R Out energised the relay should indicate A/R Out of Service.

There is a temporary 4 second Lockout whilst the relay is switched back into service.

During an autoreclose sequence if A/R Out is asserted the relay will go to Lockout. Whilst in Lockout an A/R In is required before Lockout can be exited.

#### 8. CB Status

The CB Status should be checked before any other input as correct operation of the autoreclose sequence relies upon the state of the circuit breaker being received correctly from the auxiliary contact circuit. Various connections can be used, as described in the Applications Guide.

There are separate signals provided for each phase:

CB A Open, CB B Open, CB C Open.

CB A Closed, CB B Closed, CB C Closed.

CB A indeterminate, CB B Indeterminate, CB C Indeterminate.

Ensure that with the circuit breaker in the open position, the CB Open (appropriate CB Aux input) status input is enabled. Check that with the CB in the open position, the CB Open LED is lit.



Ensure that with the circuit breaker in the closed position, the CB Closed (appropriate CB Aux input) status input is enabled. Check that with the CB in the closed position, the CB Closed LED is lit. Operate the CB manually, and ensure that it is in the closed position. Check that the CB Closed LED is lit.

The indication if the CB is Open and Closed, or not Open and not Closed is a separate CB Indeterminate LED and output for this.

### 9. CB In Service

With the CB Status correctly commissioned the CB In Service is not required to be checked. However the test is explained below:

To prevent unwanted autorecloses a CB In Service feature is provided which only allows autoreclosing to start provided the CB was in the closed position prior to a trip input being received. For the relay with Check Synchronisation the CB in Service feature includes CB Closed and Live Line. This is classified as the CB Memory and has a 2 second delayed drop off.

To facilitate commissioning the logic outputs from this function are mapped to the LED menu: CB Not In Service Alarm (which is at the end of the 2 sec delayed drop-off) and CB Memory.

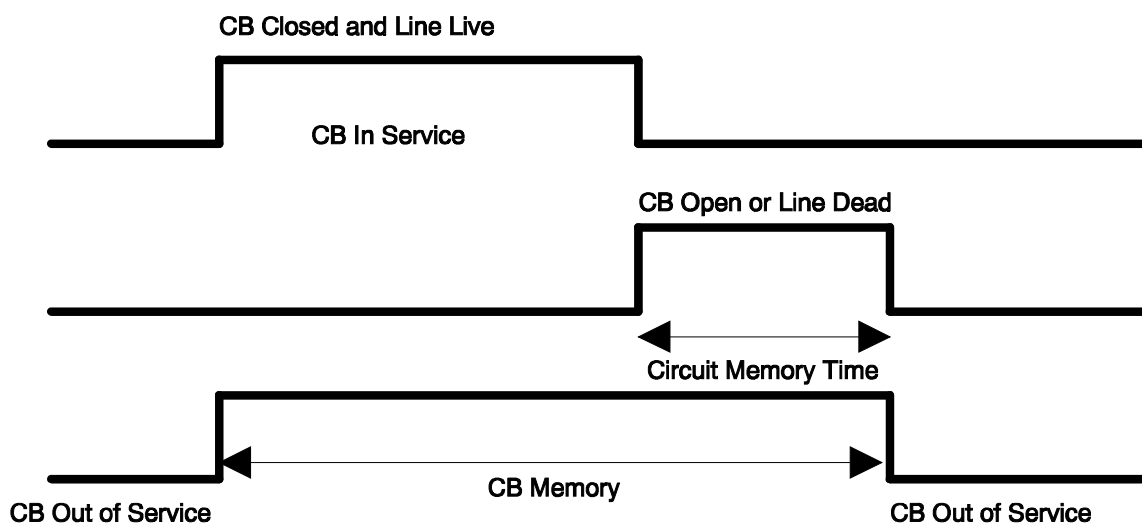

Map the CB Memory and CB Not In Service Alarm to LEDs. Manually close the CB and energise the line voltage, CB Memory should be lit. De-energise either the line or open the CB (manually open the CB), the CB Memory should reset after a 2 second delay and the CB Not In Service Alarm should be lit.

### 10. Trip and Autoreclose

Ensure that the CB is closed, and voltage is applied to both the line and bus VTs. Operate the trip status input whilst CB Memory is lit, A/R In Progress should light.

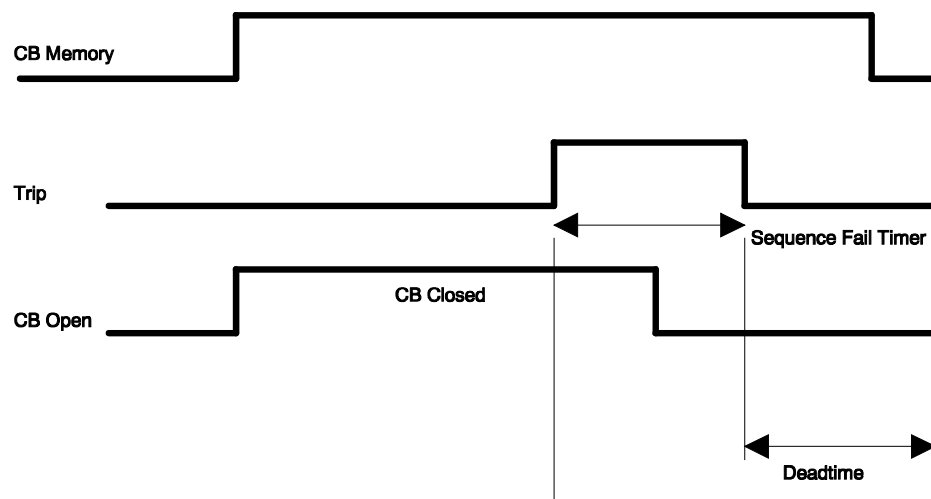

## Figure 2 Trip And Autoreclose

If a trip input occurs and CB Memory is not lit then an A/R Not Allowed indication is raised. This may be connected to cause the relay to go to Lockout, check scheme details to determine whether this needs testing.

The deadtime is started when the CB opens and the trip resets. There is a timer Sequence Fail Timer provided which can be set to go to Lockout if either the CB does not open or the trip fails to reset within the set time. This is provided to prevent the autoreclose sequence being primed indefinitely; or the Sequence Fail timer can be set to OFF.

Assuming the trip operation to be successful, the close pulse will be issued after the first deadtime setting – close the CB during the close pulse, followed by a reclaim period, before the relay returns to an idle condition, and indicates Successful Close.

If the CB is not closed during the close pulse the relay will indicate Lockout and CB Failed To Close.

### 11. Measurement of Autoreclose Time Delays

All of the time delays are proven by software testing. The autoreclose time delays may be measured to give added confidence. The measurements may be recorded using Reydisp.

Measure the Sequence Fail Timer (if applied) – Set the Sequence Fail timer to greater than the trip reset time, say 60 seconds. With CB Memory lit, energise a trip signal (start the timer), stop the timer when lockout is issued.

Measure the Deadtime time delay – To measure the deadtime the correct sequence of events must occur: Set Start Deadtime to Trip Reset. With CB Memory lit, energise a trip signal, then open the CB, de-energise the line, remove the trip signal (start the timer). Stop the timer when the Close Pulse is issued. The Close Pulse will be issued if the line is de-energised and the setting Dead Line Close is selected to Enabled.

Measure the Close Pulse – measure the duration of the close pulse which should correspond to the setting.

Measure the Reclaim time - Start at the end of the close pulse, stop when Successful Close is issued, provided the CB has closed.

Measure the Sync Close Delay (if applied) – apply Dead Line Close = Disabled, Dead Bar Close = Disabled, Check Sync Close = Enabled. Start the deadtime but do not reapply voltage, the system will wait for as long as the deadtime + Sync Close Delay before going to Lockout.

Measure the Persistent Intertrip Timer (if applied) – Energise the Intertrip Receive status input (start timer). Keep energised until Lockout is issued (stop timer).

The time delays for the Start Up Lockout Timer, In Service Lockout Timer, Minimum Lockout Timer and Lockout Delayed Drop Off Timer are set within the relay and are not adjustable, they are therefore not required to be tested.

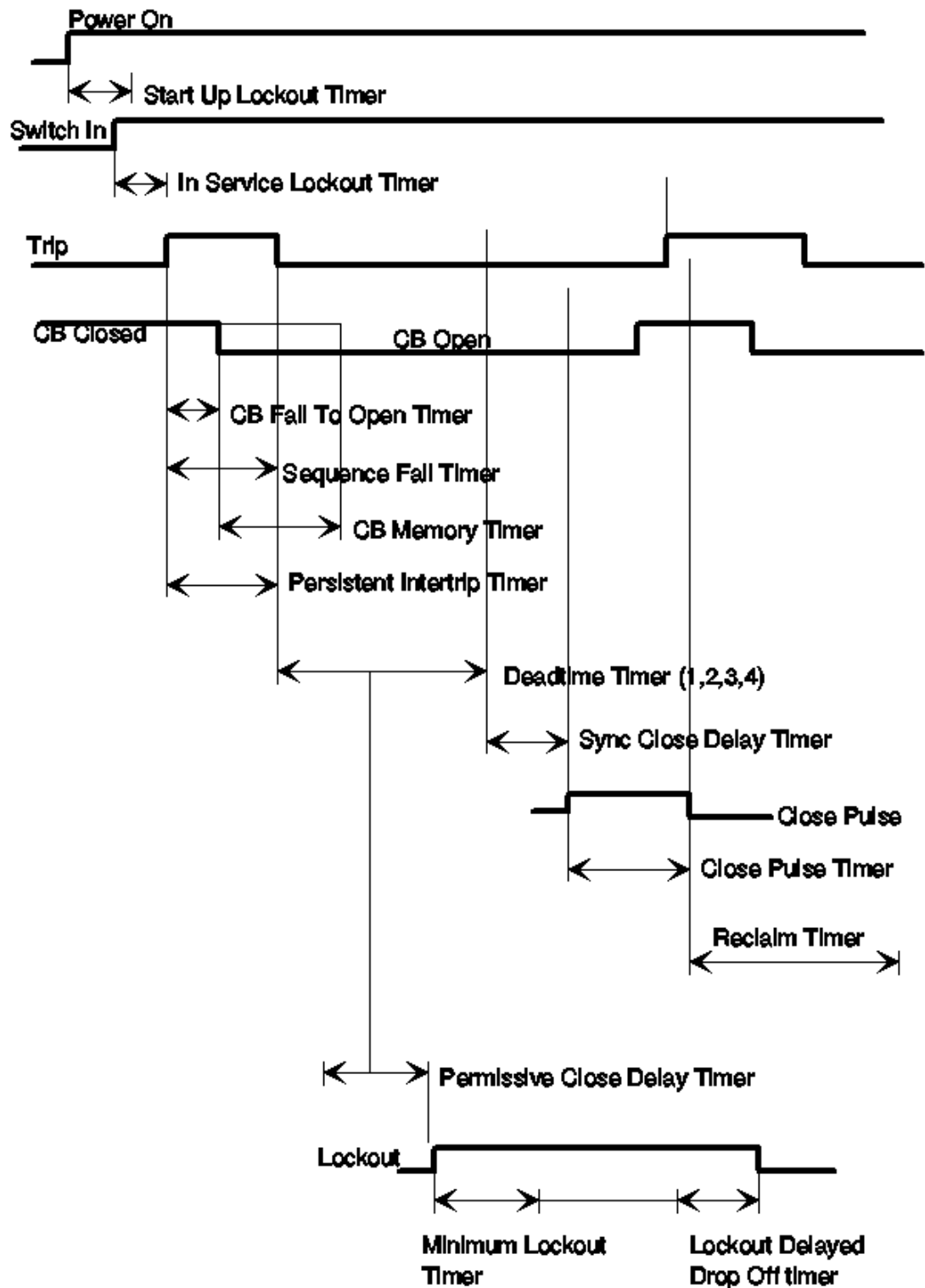

Figure 3 Autoreclose Timers

## 12. Reclose Lockout

The autoreclose sequence can be locked out at any point in the sequence provided that the A/R is In Service. Ensure that the relay is In Service, energise the Reclose Lockout status input, confirm that the relay indicates Lockout.

## 13. Manual Close

Manual Closing can occur at any point. This mimics a hard-wired close command to the circuit breaker.

With the circuit breaker closed. Operate the Manual Close input and ensure that no close pulse is issued.

Manually trip the circuit breaker. Operate the Manual Close input, and ensure that a close pulse of the programmed time is issued.

#### 14. System Closing Conditions

The test for Dead Line Closing, Dead Bar Closing or Check Sync Closing is different dependent upon whether it is a Manual Close or Autoreclose.

There are three settings associated with the circuit breaker's three pole closing conditions:

Dead Line Close Enabled/Disabled.

Dead Bar Close Enabled/Disabled.

Check Sync Close Enabled/Disabled.

The order at which these are checked is Dead Line then Dead Bar then Check Sync. However Check Sync has priority.

These settings are only relevant to Three Pole autoreclosing. Single Pole Autoreclosing does not check these settings. Also, when a Manual Close is issued the relay does not check these settings, the relay just checks the state of the system.

To test for the Manual Close conditions:

Manually open the circuit breakers. Apply voltage to indicate Live Bar and issue a Manual Close. The relay should issue a close pulse and a Dead Line Close Flag.

Manually open the circuit breakers. Apply voltage to indicate Live Line and issue a Manual Close. The relay should issue a close pulse and a Dead Bus Close Flag.

Manually open the circuit breakers. Apply voltage to indicate Live Line and Live Bar and issue a Manual Close. The relay should issue a close pulse and a Sync In Progress Flag.

To test for the three pole autoreclosing conditions:

Dead Line Closing - Ensure that the circuit breaker is closed. Select Dead Line Close = Enabled in the A/R MENU. For an autoreclosing sequence to start, the CB must be closed and the line live. Issue a 3P trip input and then open all the circuit breakers, switch off the line voltage. Keep the line voltage off to simulate a dead line close. After the first deadtime the close pulse should be issued together with a Dead Line Close Flag.

Dead Bar Closing - Ensure that the circuit breaker is closed. Select Dead Bar Close = Enabled and Dead Line Close = Disabled in the A/R MENU. For an autoreclosing sequence to start, the CB must be closed and the line live. Issue a 3P trip input and then open all the circuit breakers, switch off the line voltage. Keep the line voltage and bar voltage off to simulate a dead bar close. After the first deadtime the close pulse should be issued together with a Dead Bus Close Flag.

There are two instances where closing can be performed by Sync Check. These are either at the end of the deadtime when the system will wait for as long as the Sync Close Delay; Or during the deadtime when the system comes into synchronisation and Check Sync Close is allowed. For the latter the deadtime will be bypassed and the close pulse issued directly. To test for both of these:

Check Sync Closing at end of deadtime - Ensure that the circuit breaker is closed. Select Dead Bar Close = Disabled and Dead Line Close = Disabled and Check Sync Close = Enabled in the A/R MENU. For an autoreclosing sequence to start, the CB must be closed and the line live. Issue a 3P trip input and then open all the circuit breakers, switch off the line voltage. Keep the bar voltage live. At the end of the deadtime switch on the line voltage and bring the line and bar volts into synchronism. The close pulse should be issued together with a Sync In Progress Flag.

Check Sync Closing during the deadtime - Ensure that the circuit breaker is closed. Select Dead Bar Close = Disabled and Dead Line Close = Disabled and Check Sync Close = Enabled in the A/R MENU. For an autoreclosing sequence to start, the CB must be closed and the line live. Issue a 3P trip input and then open all the circuit breakers, switch off the line voltage. Keep the bar voltage live. During the deadtime switch on the line voltage and bring the line and bar volts into synchronism. A suitably long deadtime should be set. The close pulse should be issued together with a Sync In Progress Flag.

To test for single pole autoreclosing:

Ensure that the circuit breaker is closed. Select Close Mode Selection = 1P/3P in the A/R MENU. For an autoreclosing sequence to start, the CB must be closed and the line live. Issue an A Phase trip input and then open the A Phase circuit breaker. Keep the line voltage on to simulate a single pole open. After the first 1P deadtime the close pulse should be issued together with a 1Pole Close Flag. Repeat for other phases.

#### **15. Multi-shot Autoreclose sequence**

The relay can be programmed to perform a number of autoreclose shots.

The setting Close Mode Selection controls the number of closes.

## **6. Putting Into Service**

After tests have been performed satisfactorily the relay should be put back into service as follows :

- Remove all test connections
- Where possible, the relay settings should be downloaded to a computer and a printout of the settings obtained. This should then be compared against the required settings. It is important that the correct settings group is active, if more than one group has been programmed.
- Replace all fuses and links.

## APPENDIX 1 – Test Tables

**Table 1 – Phase Angle Tests**

Phase Element	Phase Setting (Degrees)	Positive angle		Negative angle	
		Pick Up (Degrees)	Drop Off (Degrees)	Pick Up (Degrees)	Drop Off (Degrees)
CS Phase Angle					
SS Phase Angle					

**Table 2 – Slip Frequency Tests**

Slip Element	Slip Setting (Hz)	Positive Slip		Negative Slip	
		Pick Up (Hz)	Drop Off (Hz)	Pick Up (Hz)	Drop Off (Hz)
CS Slip Freq.					
SS Slip Freq.					

**Table 3 – Timer Tests**

Timer Type	Timer Setting (sec)	Actual Time (sec)
CS Timer		
SS Timer		

**Table 4 – Voltage Element Tests**

Voltage Detector	Live Level			Dead Level		
	Setting (V)	Pick Up (V)	Drop Off (V)	Setting (V)	Pick Up (V)	Drop Off (V)
Line						
Bus						

Voltage Element	Setting (V)	Pick Up (V)	Drop Off (V)
Line Undervoltage			
Bus Undervoltage			
Differential Element			

## APPENDIX 2 - Circuit Breaker Simulation Circuit

This appendix describes the circuit used at Reyrolle to simulate circuit breaker operation during the development of the relay software, enabling the Tau to be tested in isolation from a full working circuit breaker.

The circuit consisted of a two coil, magnetic latching bistable relay, which operated from trip and close signals. The latching relay was used to drive a 5 volt, 8mm relay, with double pole, changeover contacts. These contacts were then used as follows:

- One pair of normally closed contacts was used to drive the CB OPEN status input of the TAU to provide circuit breaker position information for the trip and close operation tests.
- One pair of normally open contacts was used to simulate the circuit breaker main contacts.

The circuit used is shown in figure A1 below. Any suitable latching relay could be used. Alternatively, two 8mm relays connected as in figure A2 could be used in place of the magnetic latching relay.

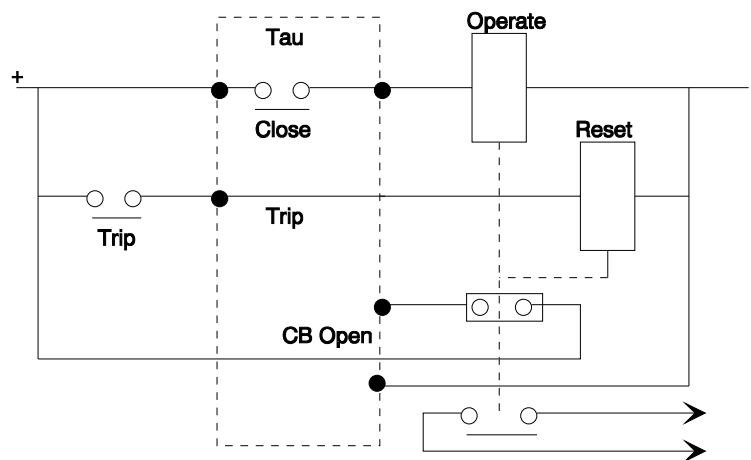

Figure A1

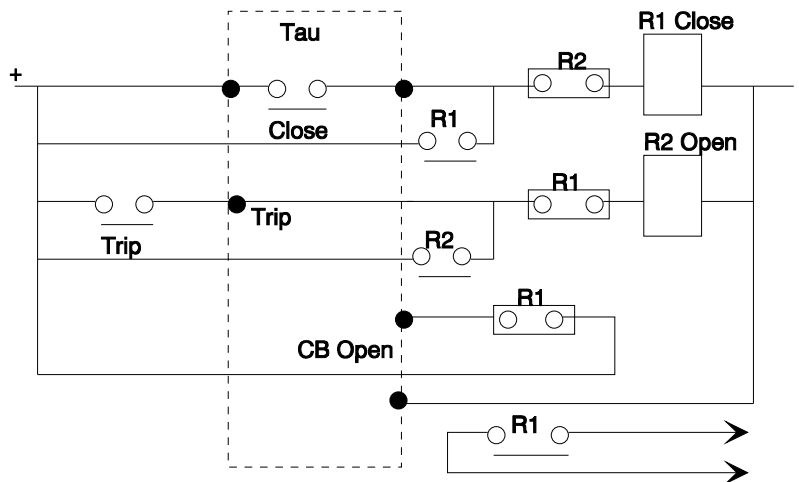

Figure A2